

# IAQ 2016 Defining Indoor Air Quality: Policy Standards and Best Practices

Carsten Rode, Ph.D.,  
Technical University of  
Denmark  
[car@byg.dtu.dk](mailto:car@byg.dtu.dk)  
presented by  
Jelle Laverge, Ph.D.,  
Ghent University

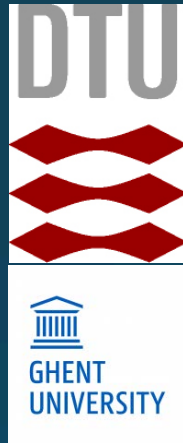

IEA-EBC Annex 68

Indoor Air Quality Design and Control in Low Energy Residential Buildings

An International Project on  
Indoor Air Quality Design and Control in  
Low Energy Residential Buildings  
*IEA EBC Annex 68 Project*

# Motivation

- Awareness of changes in the global climate has put increasing pressure on the reduction of energy consumption in buildings.
- As the general standard of insulation has been increasing, the focus is on other means to reduce energy consumption.
- Ventilation (natural or mechanical) is another obvious candidate.
- Less ventilation, however, can lead to increased levels of pollutants indoors.
- How do we ensure that future low-energy buildings provide a comfortable and healthy indoor environment?

*Prof. Geo Clausen, DTU*

*Building Green Fair, Copenhagen, 30 Oct. 2014*

# Problem Statement

- Highly energy efficient buildings are airtight buildings, and their need for ventilation should be optimized
  - but may be energy consuming
- Risk of high levels of pollutants indoors: Humidity, CO<sub>2</sub> and chemical compounds
  - Influence of materials in the building fabric and inventory of buildings



# Indoor Atmospheric Situation

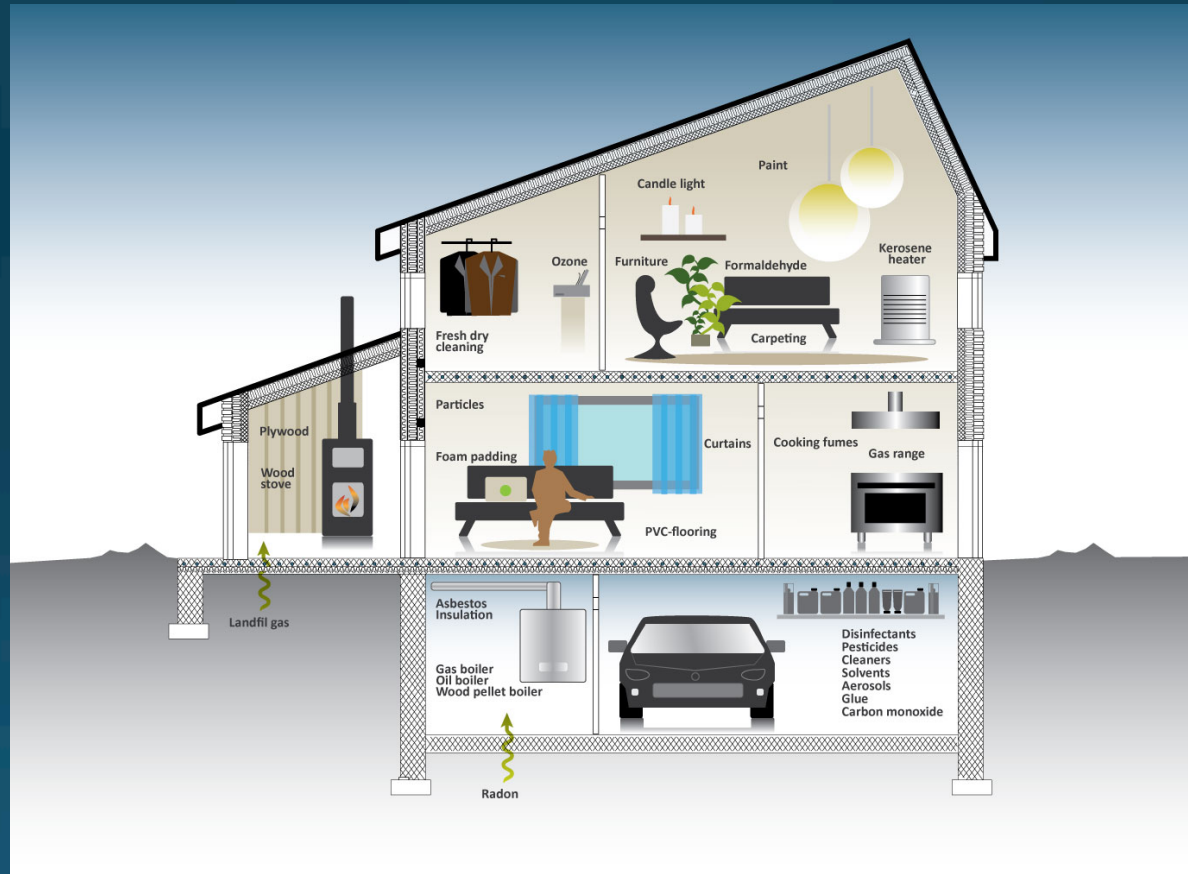

# Objective

- To provide a **generic guideline** for the **design and operational strategy** of residential buildings, which have minimal energy use, and at the same time maintain a very high standard regarding Indoor Air Quality based on the control of sources, sinks and flows of heat, air, moisture, and pollutants under in-use conditions.
- This will be done by gathering the existing scientific knowledge and data on pollution sources in buildings, models on indoor hygrothermal and air quality as well as thermal systems, and by looking to ways to optimize the provision of ventilation and air-conditioning.
- Gaps of knowledge will be identified and filled, not least by establishing links between knowledge that exists in the field of indoor air chemistry, modelling, and HVAC technology and controls.

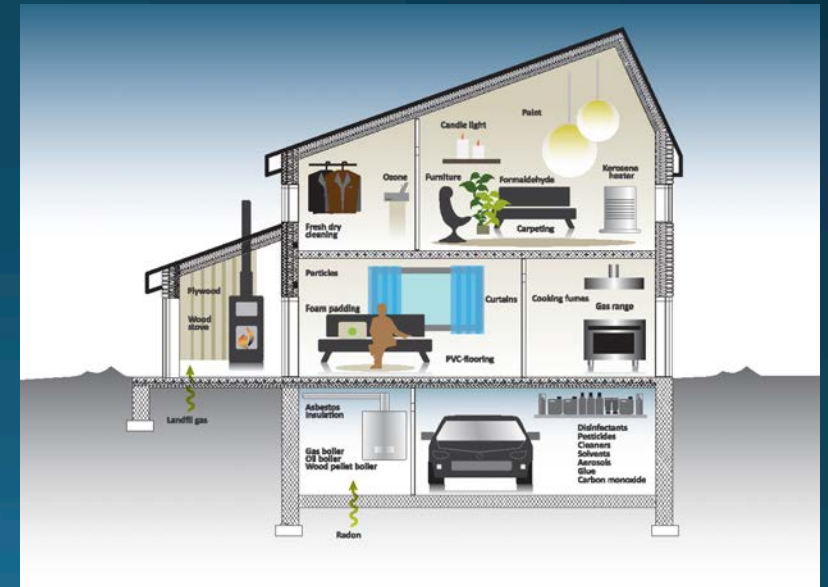

# Structure

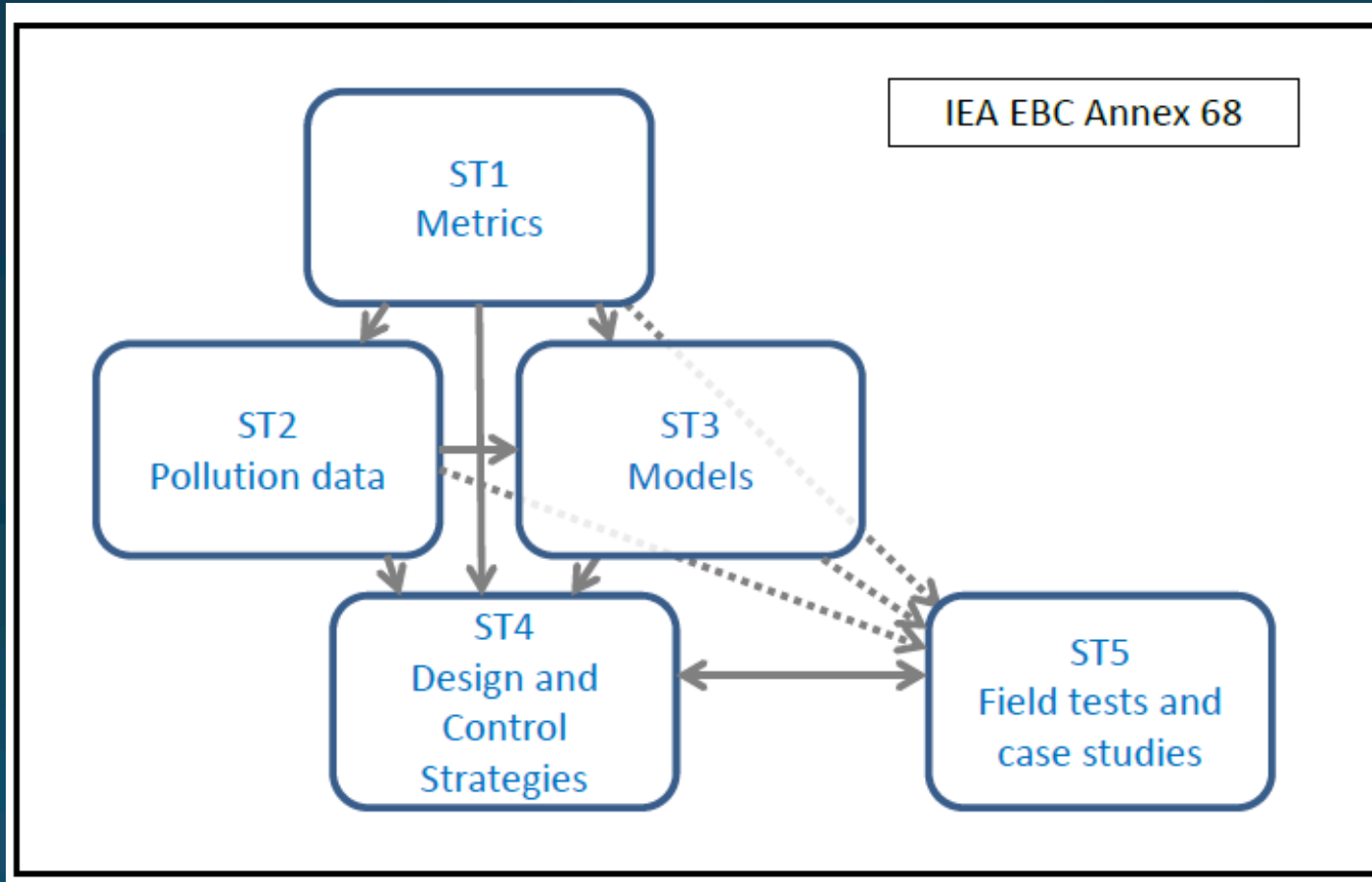

# Subtasks

- ST1 - Defining the metrics
- ST2 - Pollutant loads in residential buildings
- ST3 - Modeling
- ST4 - Strategies for design and operation
- ST5 - Field measurements and case studies



# ST 1 (leads: F, DK) – Defining the metrics

- Identify the indices and markers, which can be used to quantitatively:
  - describe the IAQ, and
  - allow comparison with the indices describing energy use.
- The metrics would allow quantifying the benefits of different methods for achieving high IAQ and compared in parallel with consequences for energy and greenhouse gas emission.





### Indoor Air Pollution

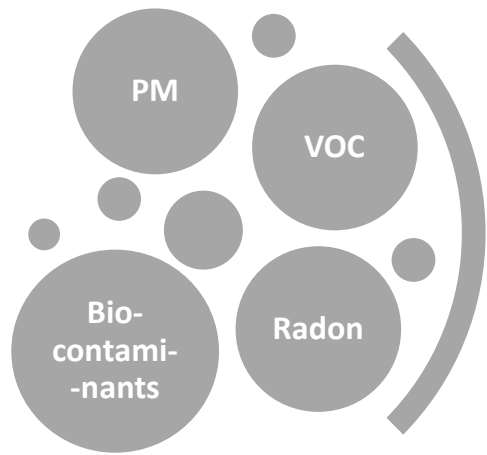

### Target pollutants

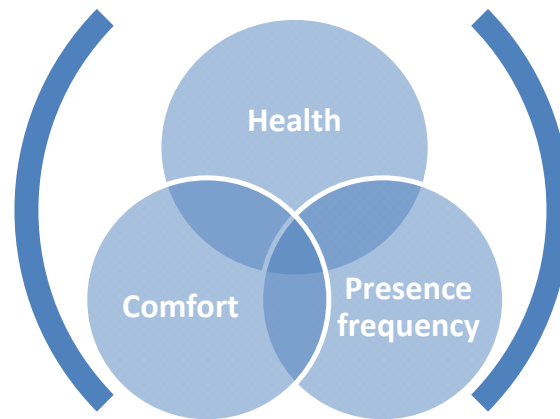

### Metrics

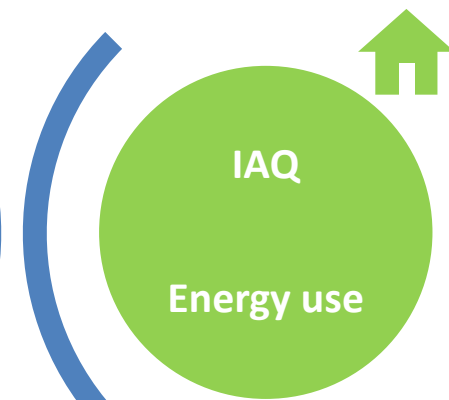

# Pollution levels in residential buildings

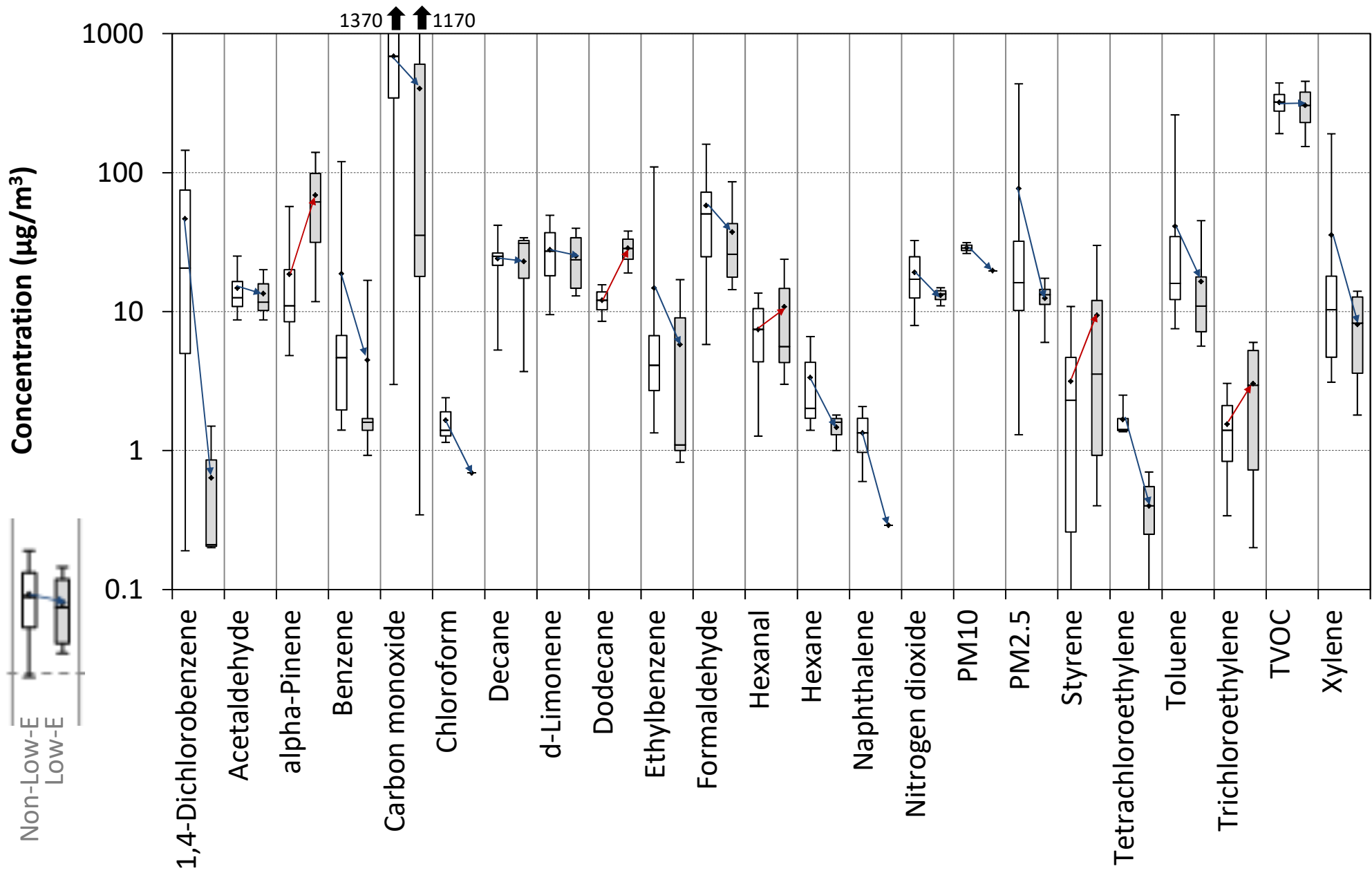

## Low-energy buildings

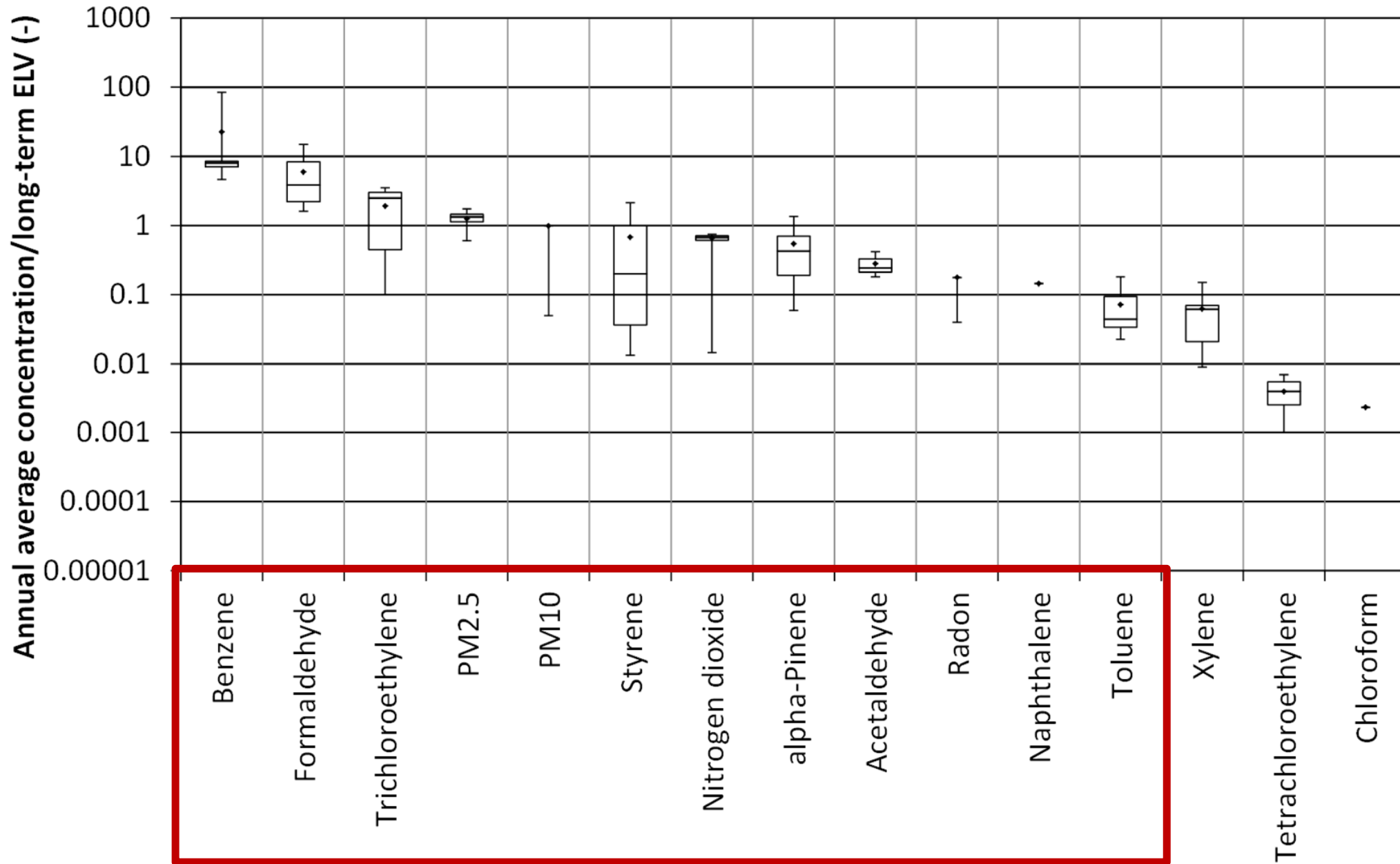

+ pollutants according to previous studies on pollutant prioritization (WHO, INDEX, ...)

# Metrics for Annex68 – Dashboard

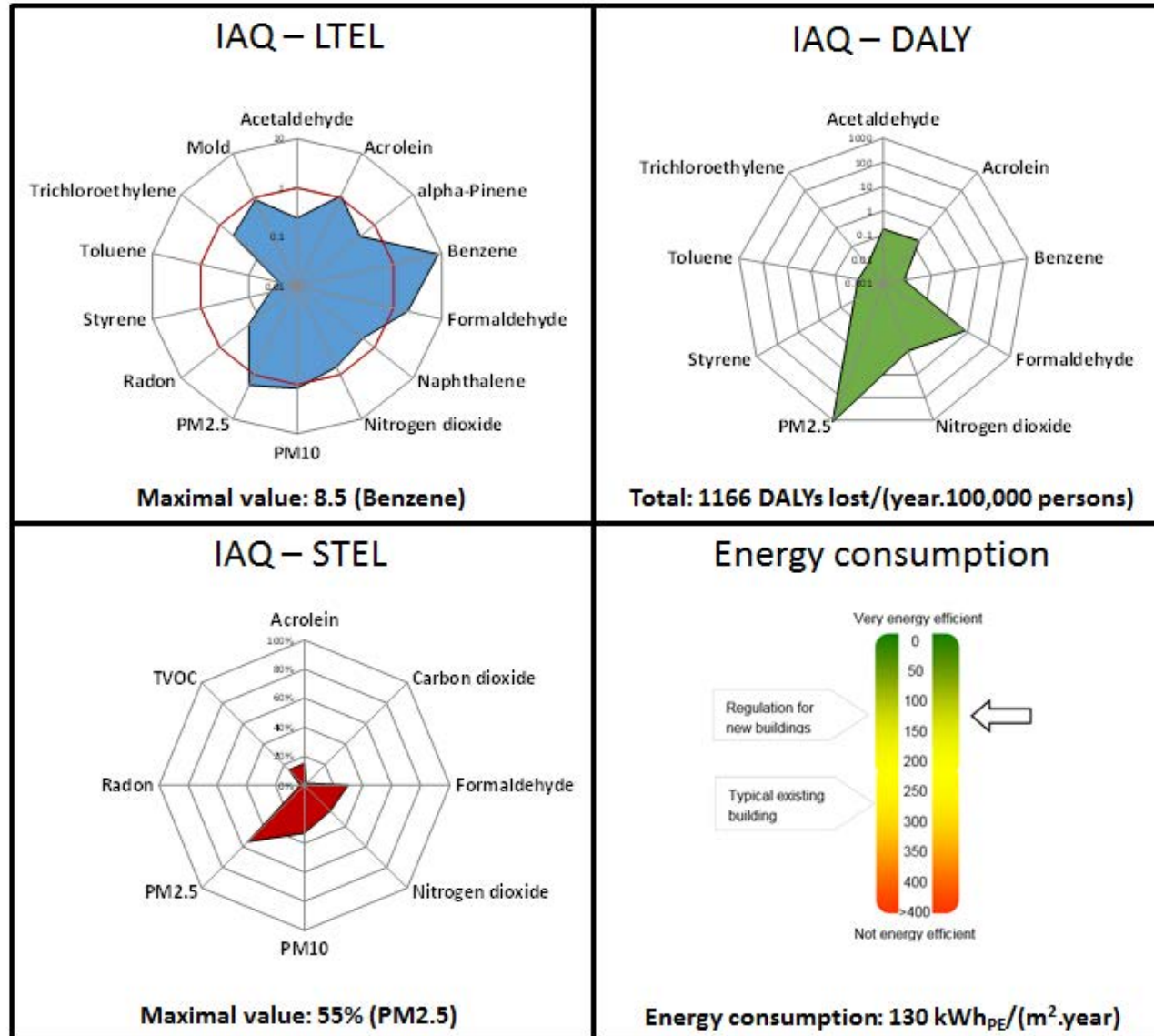

Data represented here are just for display and do not represent actual situation

## ST 2 (leads: CN, USA)

# Pollutant loads in residential buildings

Results will be collected and analysed from tests of emission of harmful compounds under various temperature, humidity and air flow conditions, and supplemented where such data under combined exposures generally do not exist today.

- 2.1 Literature survey to gather relevant data and existing knowledge on pollutant loads in buildings, including model
- 2.2 Laboratory testing and model setup to provide examples of new data, which will improve knowledge on combined effects that must be taken into consideration.



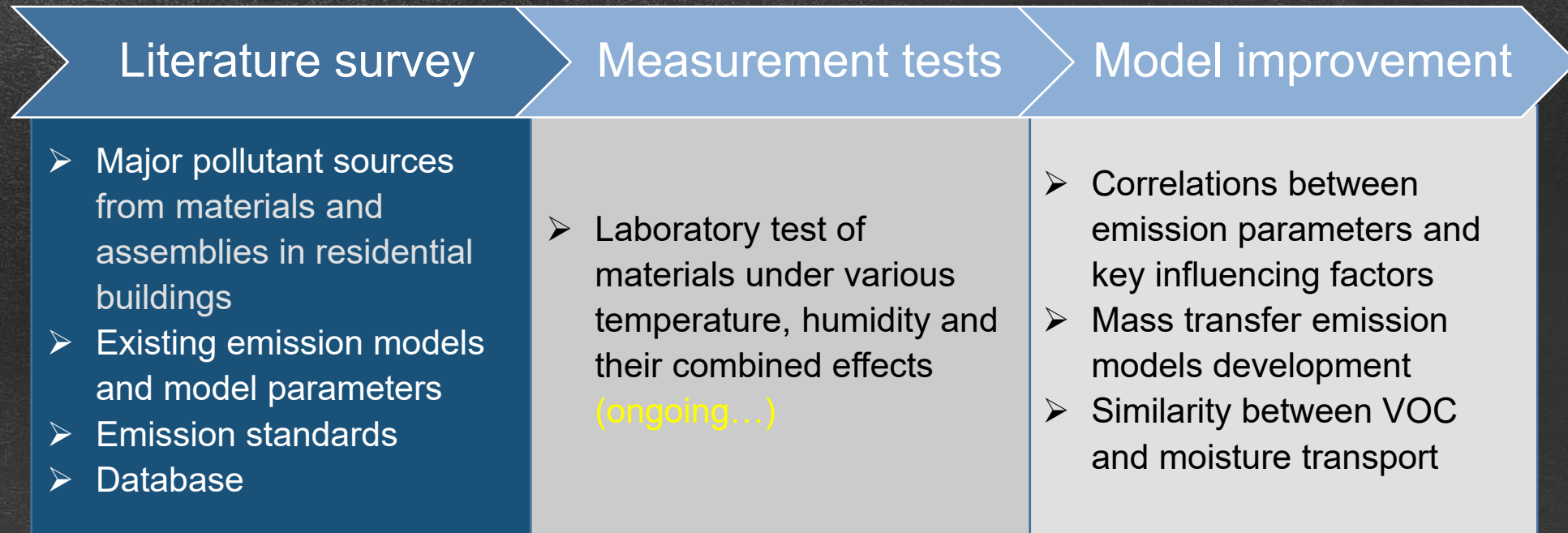

## Time schedule

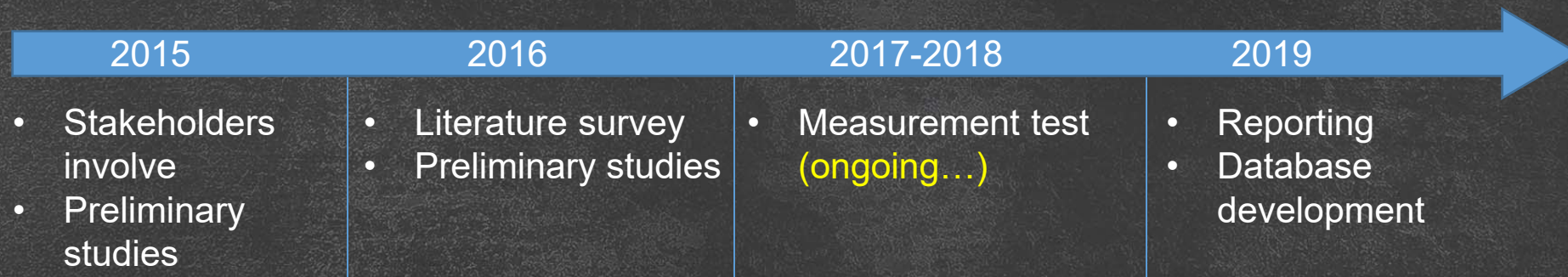

## Temperature and humidity influences on the emission rate of formaldehyde and VOCs in building materials

- ◆ Temperature and relative humidity can simultaneously change in indoor environment, which significantly affect the emission rate of formaldehyde and VOCs from building materials.
- ◆ Previous studies mainly focus on the single effect of temperature OR relative humidity, and the combined effect is not considered.
- ◆ Study on the emissions of formaldehyde and VOCs from building materials can be divided into two approaches: modelling and experimental measurement.

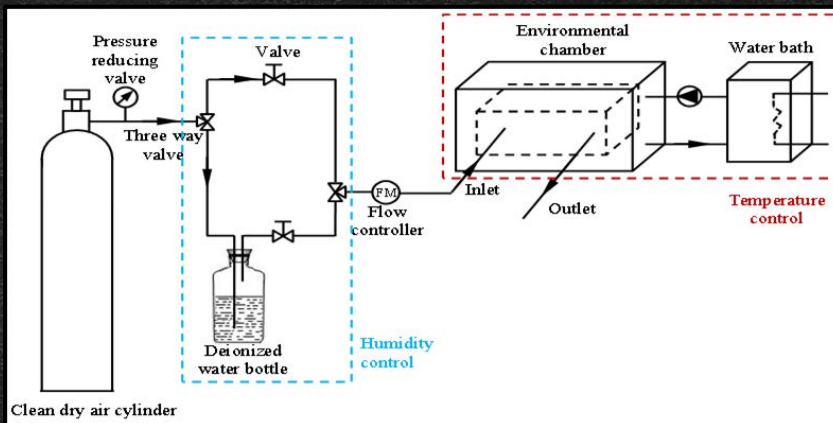

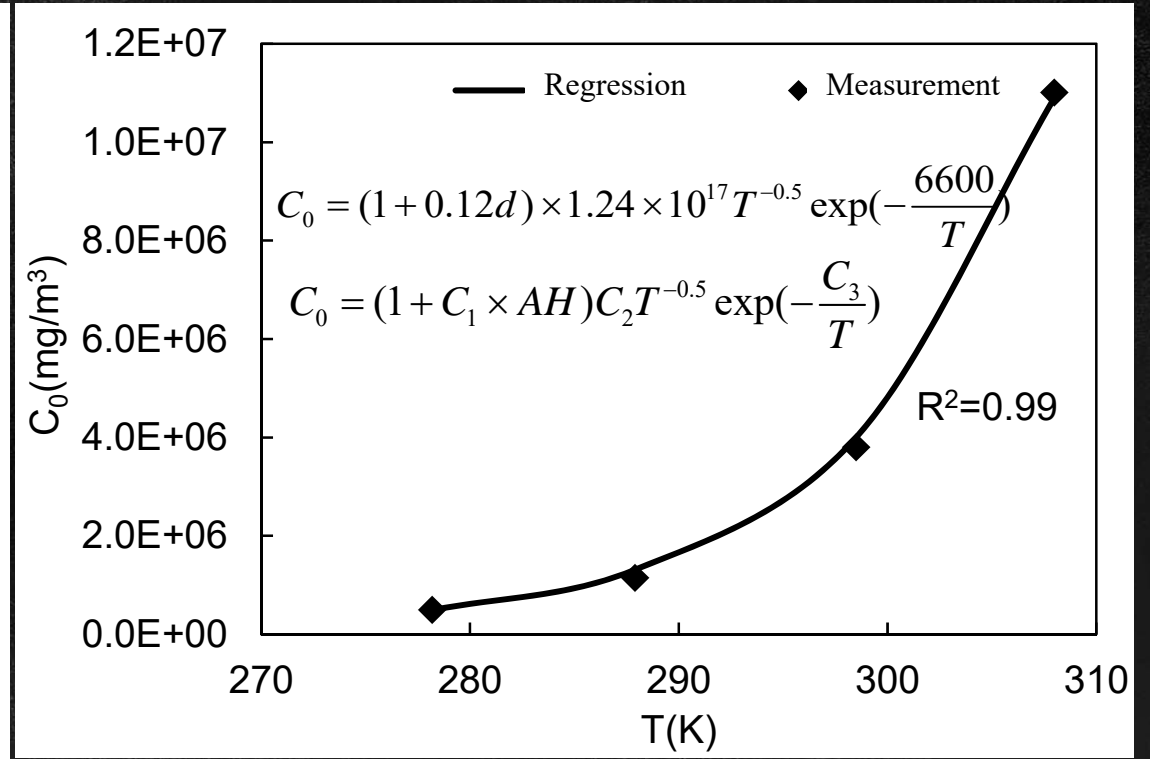
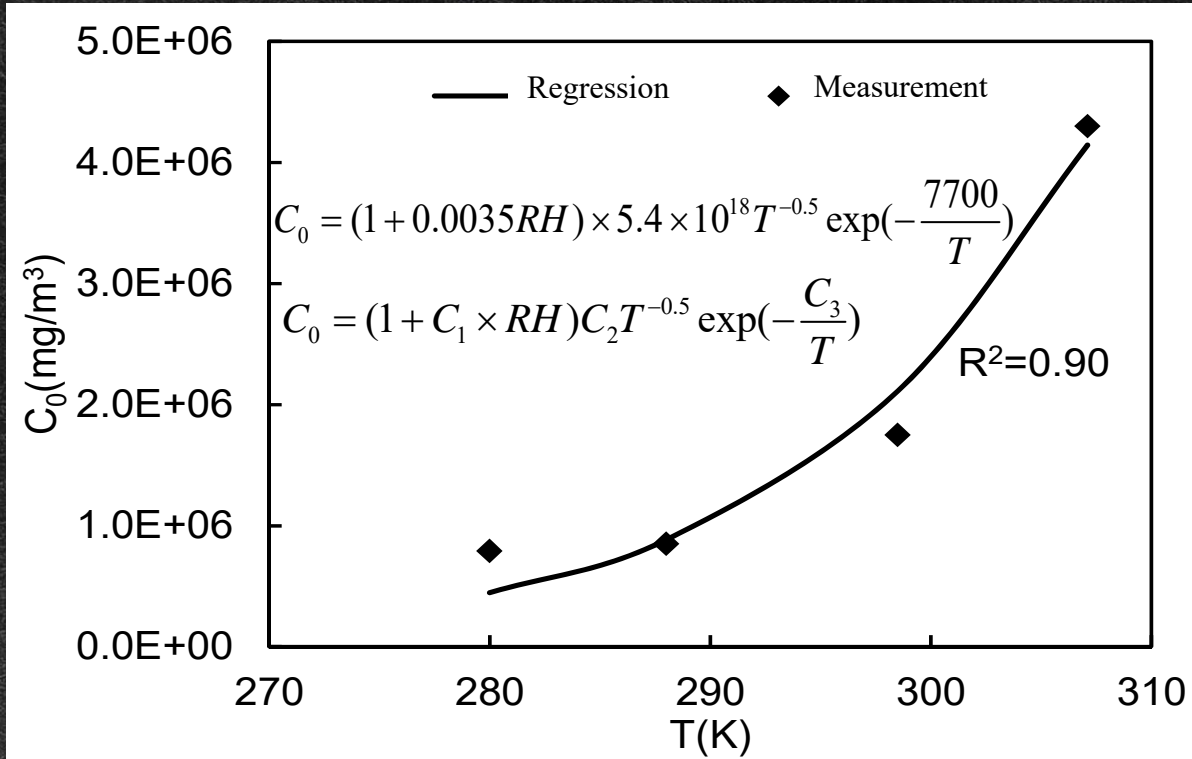

	$C_1$	$C_2$	$C_3$
$C_0$	0.0035	$5.4 \times 10^{18}$	-7700
$D_m$	$7.14 \times 10^{-17}$	-284	
K	0.225	2188	

	$C_1$	$C_2$	$C_3$
$C_0$	0.12	$1.24 \times 10^{17}$	-6600
$D_m$	$5.18 \times 10^{-17}$	-194	
K	0.12	2376	



## ST 3 (leads: D, USA)

# Modelling - review, gap analysis & categorization

Collection and development of knowledge regarding whole building analysis tools and methods to predict the hygrothermal conditions, absorption and transport of humidity and chemical substances, and energy use within whole buildings.

Focus on methods to predict the emission and absorption of chemical compounds from materials under realistic in-use conditions regarding the CHAMPS-exposure in buildings.

Predominantly building upon existing BES tools and IEA EBC Annex 60 based tools/models.







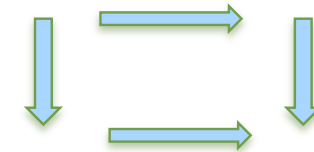

## CHAMPS-Multizone (pre NANDRAD)

- Model components:

- A set of 1D constructions solved with DELPHIN/CHAMPS-BES (transient, PDE)
- A multi-zone air flow network for air flow calculation (quasi-steady state, linear equation system)
- Multi-zone energy, moisture and pollutant balances (transient, set of ODEs)



Zone 1			
Zone 2			
Zone ...			

# Example for FMI usage

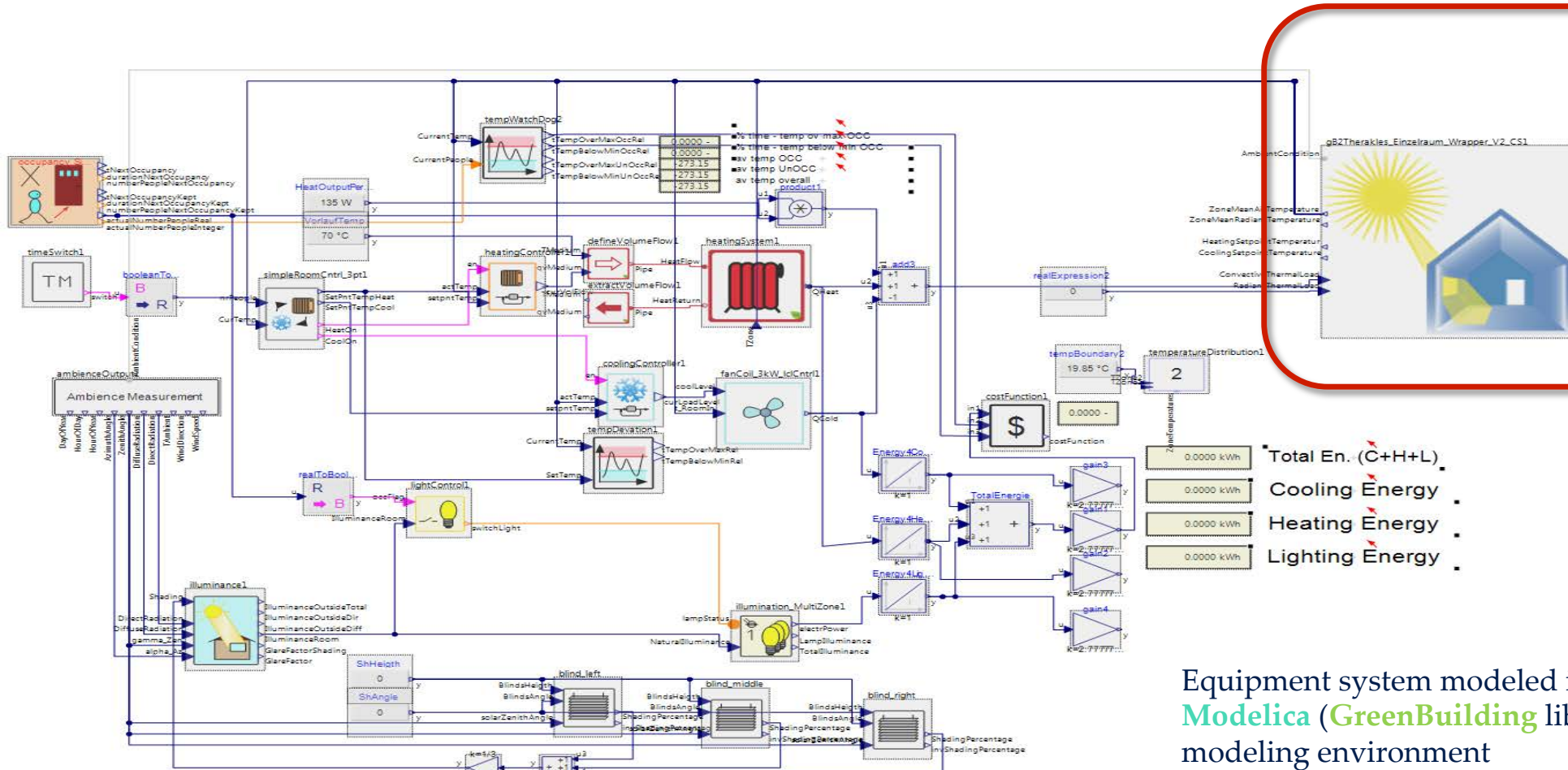

Building represented by  
single-zone model  
THERAKLES (IBK)

Equipment system modeled in  
**Modelica** (GreenBuilding library) with SimulationX  
modeling environment  
and simulator

Modelica model by Fraunhofer EAS, Dresden

## The Waveform Relaxation Method

Iteration algorithms (run until *convergence* based on *exchanged time series* → vector norm):

(a) Gauss-Jacobi relaxation

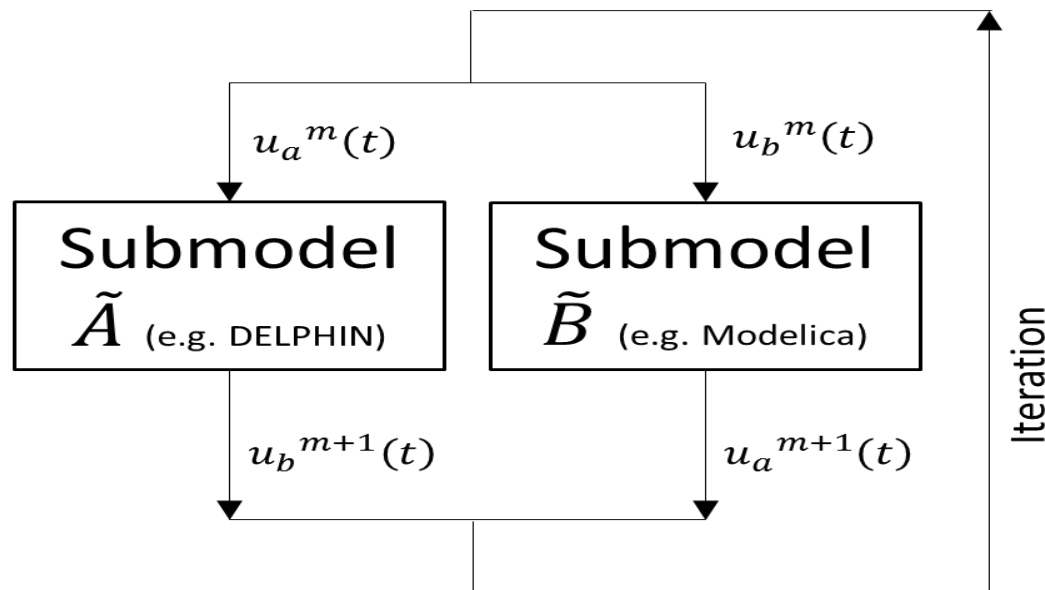

(b) Gauss- Seidel relaxation

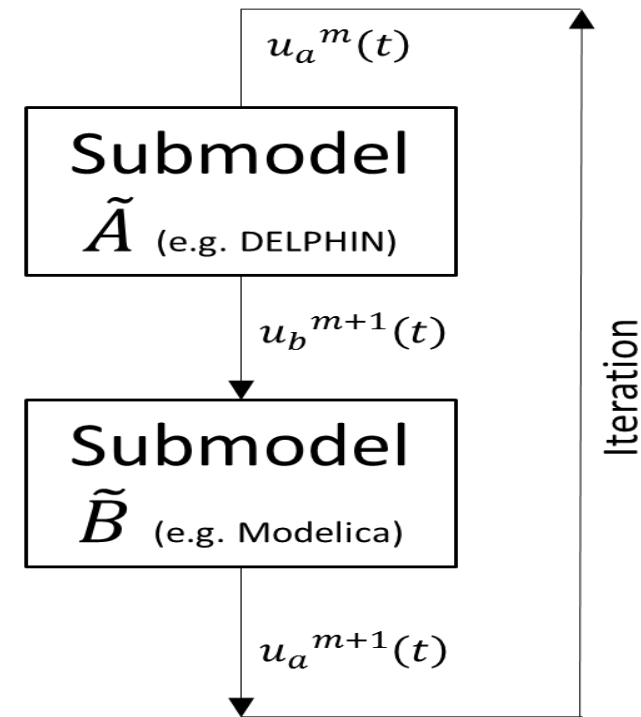

## Application Example – DELPHIN + Modelica

- Iteration progress – heat pump runs always
  - Mind: each model runs simulation over the entire simulation period (here, 14 days)
  - The information of one model progresses into the other
  - Already after a few iterations the fully coupled solution is approached

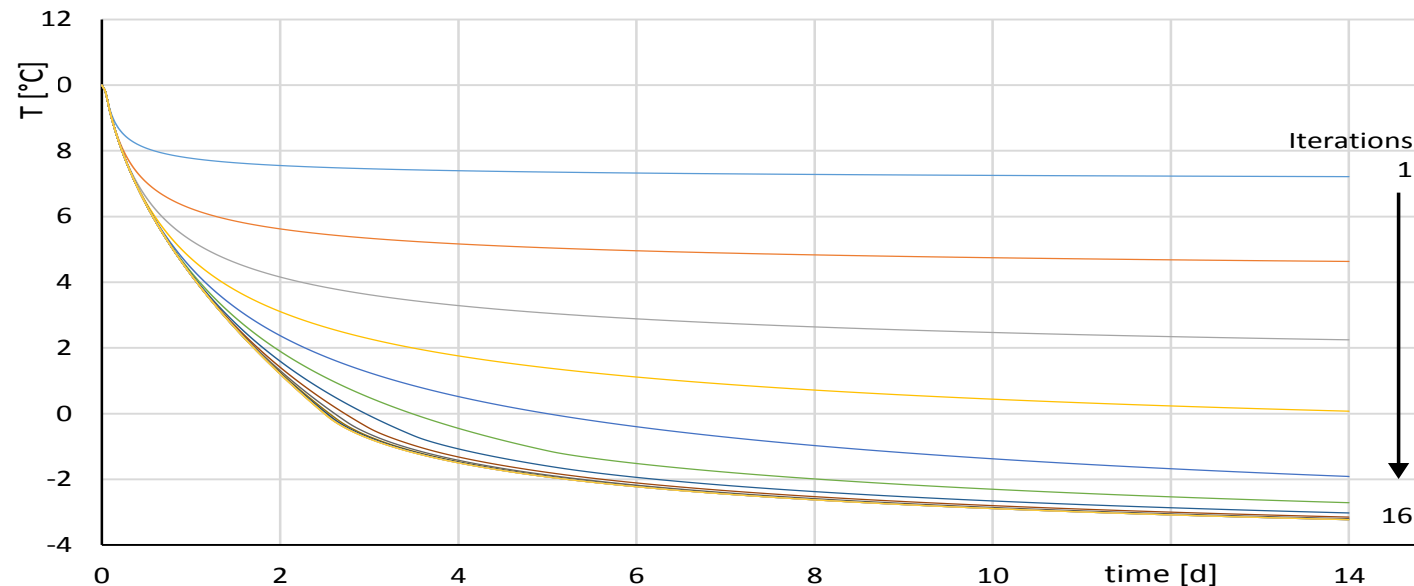

## Application Example – DELPHIN + Modelica

- Iteration progress – heat pump runs always
  - Mind: iteration progress depends on initial condition
  - Yet, results are always the same (stable convergence)

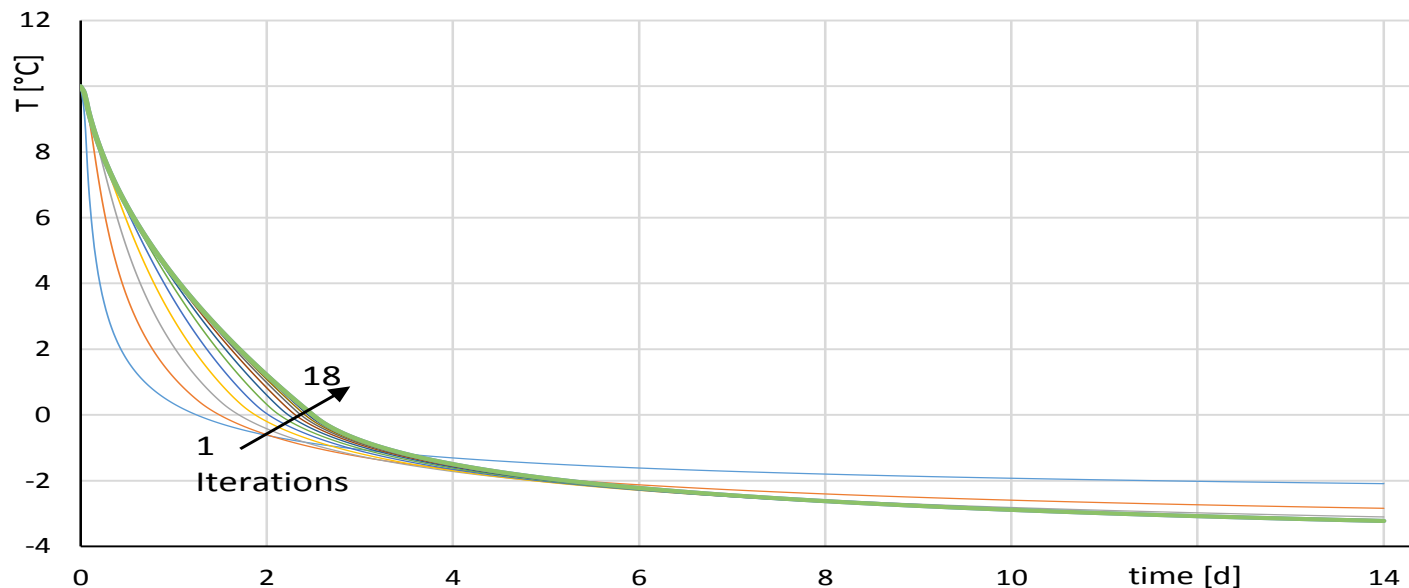

## Application Example – DELPHIN + Modelica

- Iteration progress – heat pump runs scheduled, soil regenerates
  - takes a few iterations (simulation runs) more until convergence

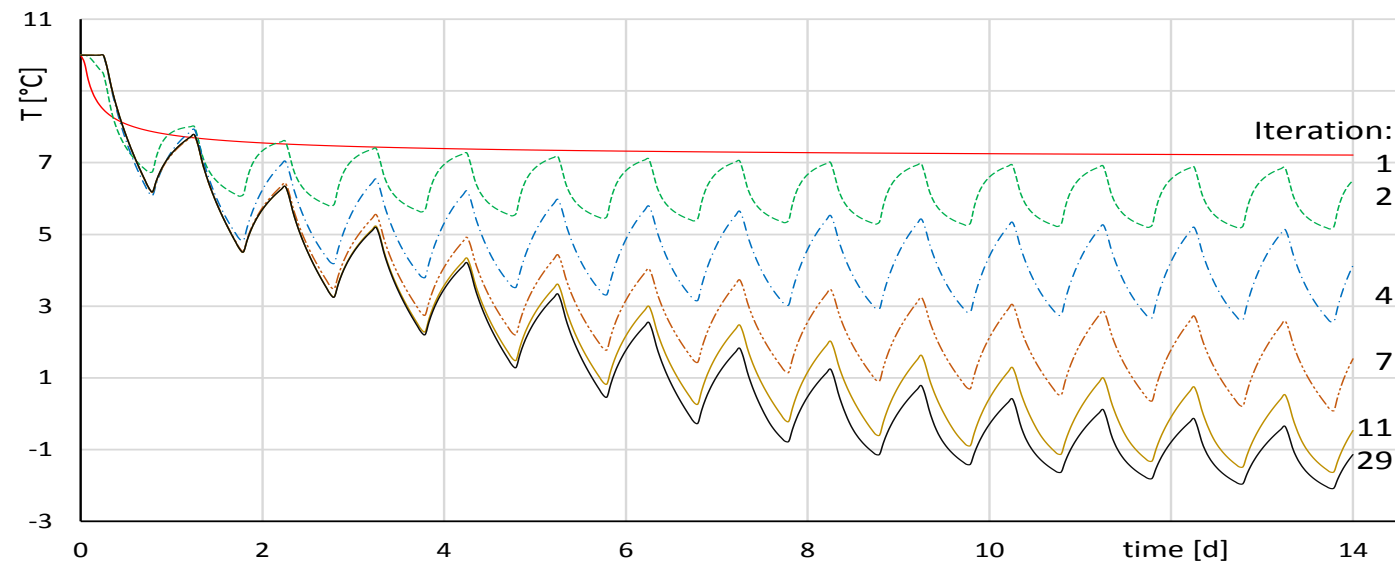

**ST4 (leads: DK, N)**

# Strategies for design and control of buildings

Devise optimal control strategies for operation of residential buildings, not least with regards to ventilation requirement and ventilation mode, such that the building energy performance, user comfort and health conditions can be optimal

- 4.1 Review of relevant international information sources/ activities related to IAQ design and control in residences.
- 4.2 Investigation of possible design strategies
- 4.3 Investigation of possible operational strategies
- 4.4 Preparation of an Annex 68 guide

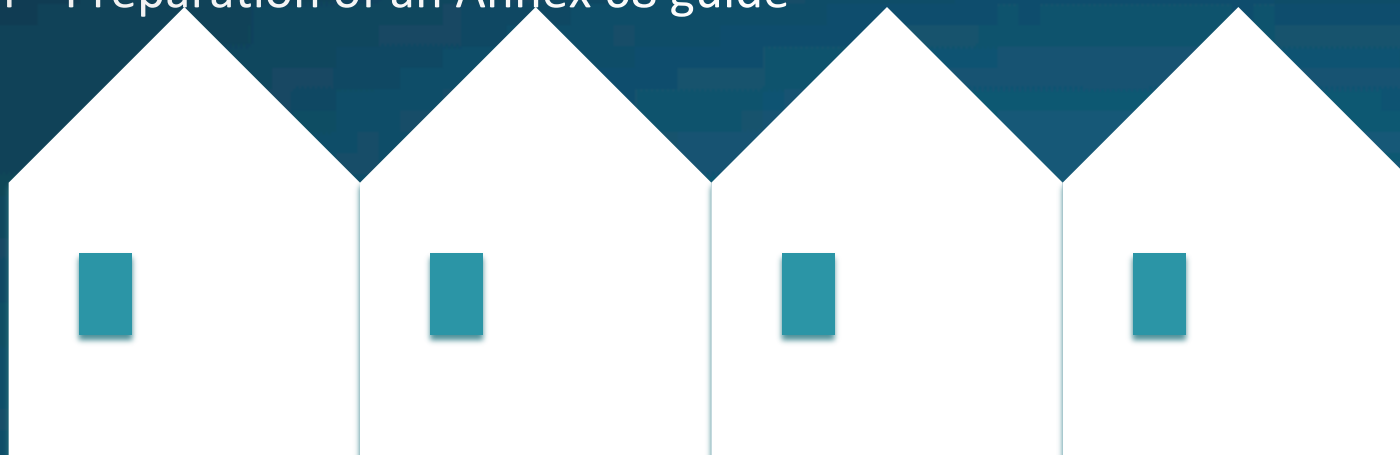



# General Gantt chart

Activity	2016		2017		2018		2019 (reporting)	
4.1 State of the art	X	X						
4.2 Design strategies		X	X	X	X			
4.3 Control & operation				X	X	X		
4.4 Annex 68 Guide		X	X	X	X	X	X	X

# Interview guidelines - example

Annex 68, Subtask 4 Strategies for design and control of buildings

## Stakeholder interview guide A: Ventilation designers/Consultants

### General information regarding the interview

Interviewer name, company/institution and contact details:			
Date of interview:		Time (hh:mm-hh:mm):	Recorded? <input type="checkbox"/> Via e-mail? <input type="checkbox"/>
Interviewees name <sup>(*)</sup> :		Age <sup>(*)</sup> :	Gender <sup>(*)</sup> :
Contact to interviewee <sup>(*)</sup> (e-mail, phone, postal address):			
Job title <sup>(**)</sup> :		Placement in organization <sup>(**)</sup> :	How long time has the interviewee been in the business? .....
Name of company/institution:			
Address of company/institution (including country):			

<sup>(\*)</sup> You need clear accept from the interviewee to write down this information.

<sup>(\*\*)</sup> For example: technical sale-coordinator, CEO, key account manager, senior specialist, etc.

<sup>(\*)</sup> For example: customer support department, sales, dept. of building design, etc.

### State of the art

#### A1. What is your involvement/experience with different ventilation concepts in residential housing?

- *What is the number of new constructions?*
- *Has there been any energy efficient refurbishments in the past? If yes, when and what type of refurbishment measures have been applied?*
- *What is the typical construction/residential housing size (floor area, m<sup>2</sup>)?*
- *What type of ventilation system is installed in the housing?*
- *Elaborate on the types of the systems: Natural/hybrid/mechanical exhaust/balanced ventilation. Centralised/decentralised. With/without heat recovery, etc.*
- *What are the typical sound protection measures used? (siding block silencers, louver flaps, etc.)*
- *What are the typical frost protection measures implemented?*
- *How is the integration of additional "ventilation-influencing" appliances handled? (cooker hood, woodstove, etc.)*

- *What type of heat recovery system is typically installed? (cross flow heat exchanger, shell and tube heat exchanger, plate heat exchanger, recuperator, etc.)*
- *Which computational tools are used during the design process?*
- *How efficient is the system in delivering the outdoor air to each location in the room?*
- *Are there any solutions/recommendations from industry?*
- *What type of air tightness testing method is usually performed?*
- *What type of methods for duct and component sizing do you use?*
  - *velocity method*
  - *constant pressure loss method (or equal friction method)*
  - *static pressure recovery method*
- *What are the typically used preferences for duct routing and typically used duct materials?*
  - *preference (square, rectangular, duct routing)*
  - *material (galvanized steel, aluminum, polyurethane, fiberglass etc.)*
- *What type of user/instruction guide do you provide to the users?*

#### A2. What are the indoor air quality requirements?

- *Which IAQ classification schemes, guidelines or standards are applied?*
- *What is the typical procedure for determining supply/extract air rates? (typical values, used standards, tools, etc.)*
- *What are the national requirements of using natural/hybrid ventilation?*

#### A3. What type of automatic control system to regulate the flow rate and flow balance is integrated with the ventilation system?

- *How does the control look like? (centralized, in each apartment, thermostat, T supply =f(Treturn), CAV/VAV based on CO<sub>2</sub>/Ti, window sensors, etc.)*
- *Do the control strategies include user control options and to what extent? (switch on and off the unit, to change ventilation intensity, to set operation mode, etc.)*

### Barriers, problems and needs

#### A4. What are the main problems/barriers during the design process of ventilation system?

#### A5. What are the main problems during commissioning and operation (including maintenance)?

#### A6. What are the main needs you perceive as a ventilation designer/consultant to ensure high indoor air quality and high energy efficiency in residential buildings?

- *Changes in the legislative regarding requirements or maintenance, etc.?*
- *Standardization, certification, EU legislative?*
- *Support from the government regarding energy effective ventilation?*

# Ventilation for renovated apartments

## Centralized

- No space for ductwork
- Difficult to plan and install

## Single-room ventilation

- Drilled installation
- Low fan power
- Local control of heat recovery

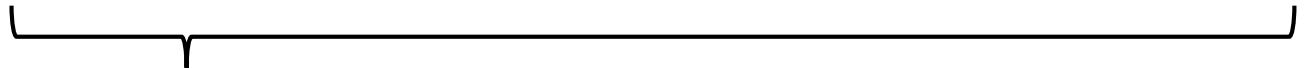
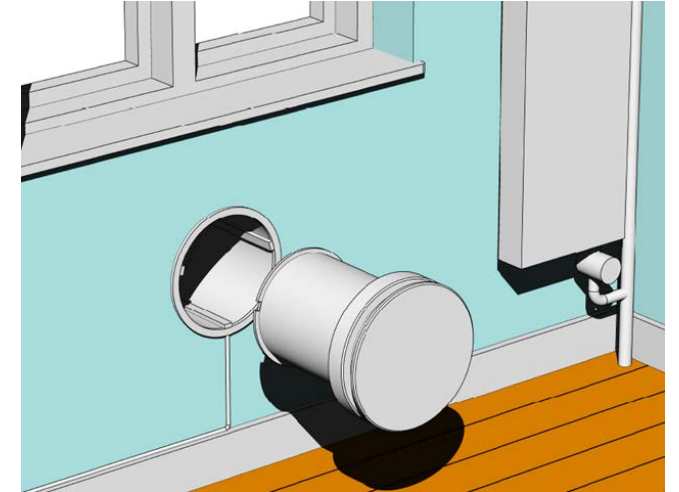

- Development with DTU: Rotary H.Ex. (Breathe 55) & Plate H.Ex. (Spiralflow)

# Three control modes (priority from L to R)

Frost protection → Humidity control → Temperature control



## ST5 (lead: B, N)

# Field measurements and case studies

This subtask is to carry out field tests and analysis of residential buildings that can be used to test and verify the findings of the other subtasks. Several sites/climates will be comprised.

- 5.1 State of the art and measurement strategy
- 5.2 Controlled measurements: In labs and test houses
- 5.3 In situ measurements: Examples of residential buildings, which are either new or existing (possibly retrofitted)
- 5.4 Analysis and dissemination



# Passys experiment

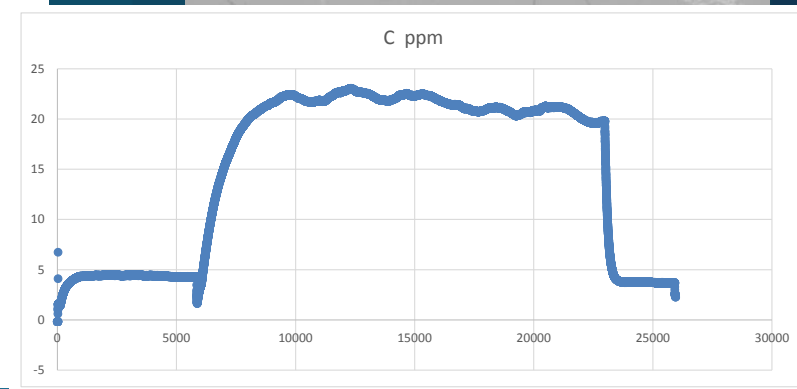
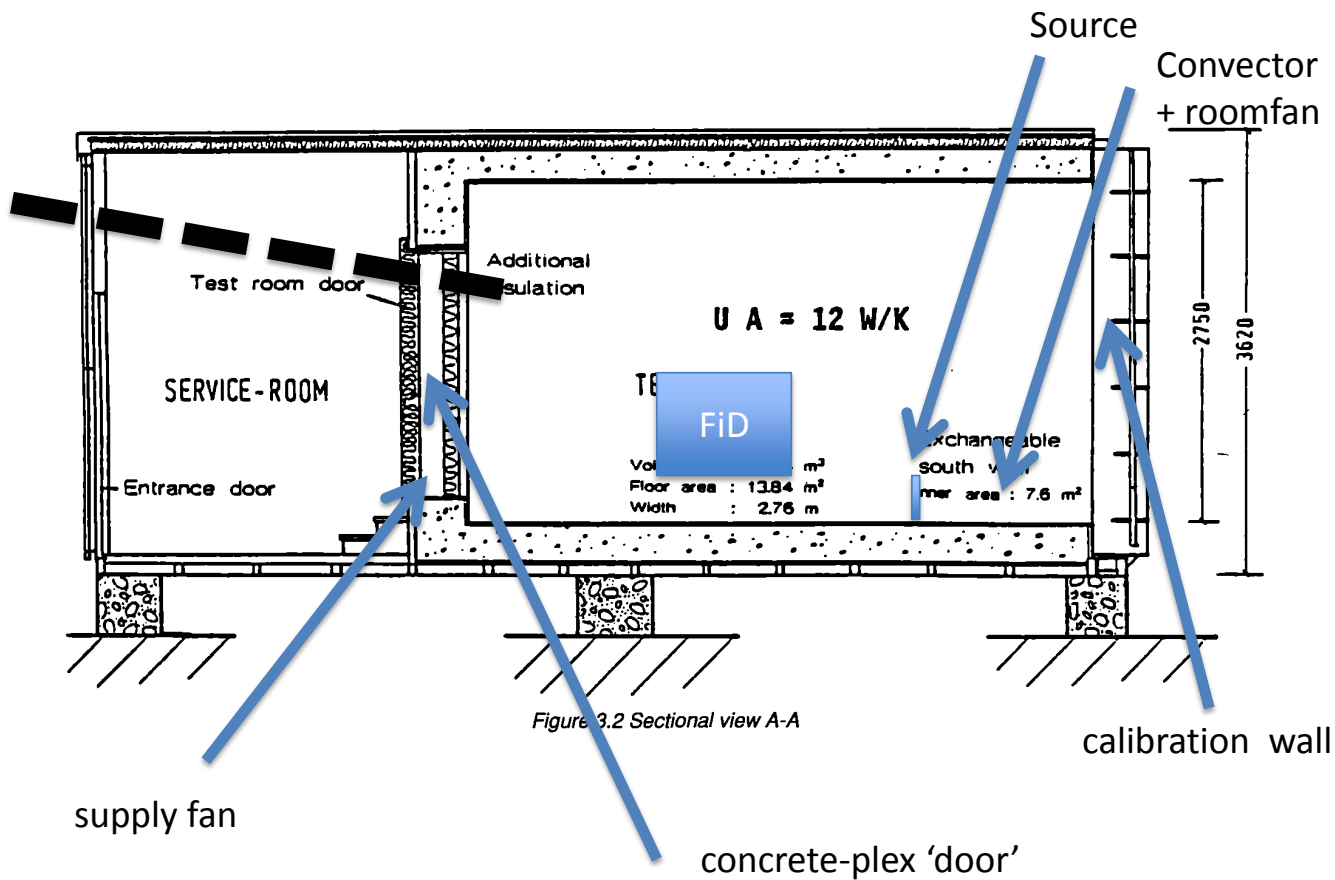

# 1. Background of home inspection

## Distribution of the researched kindergartens

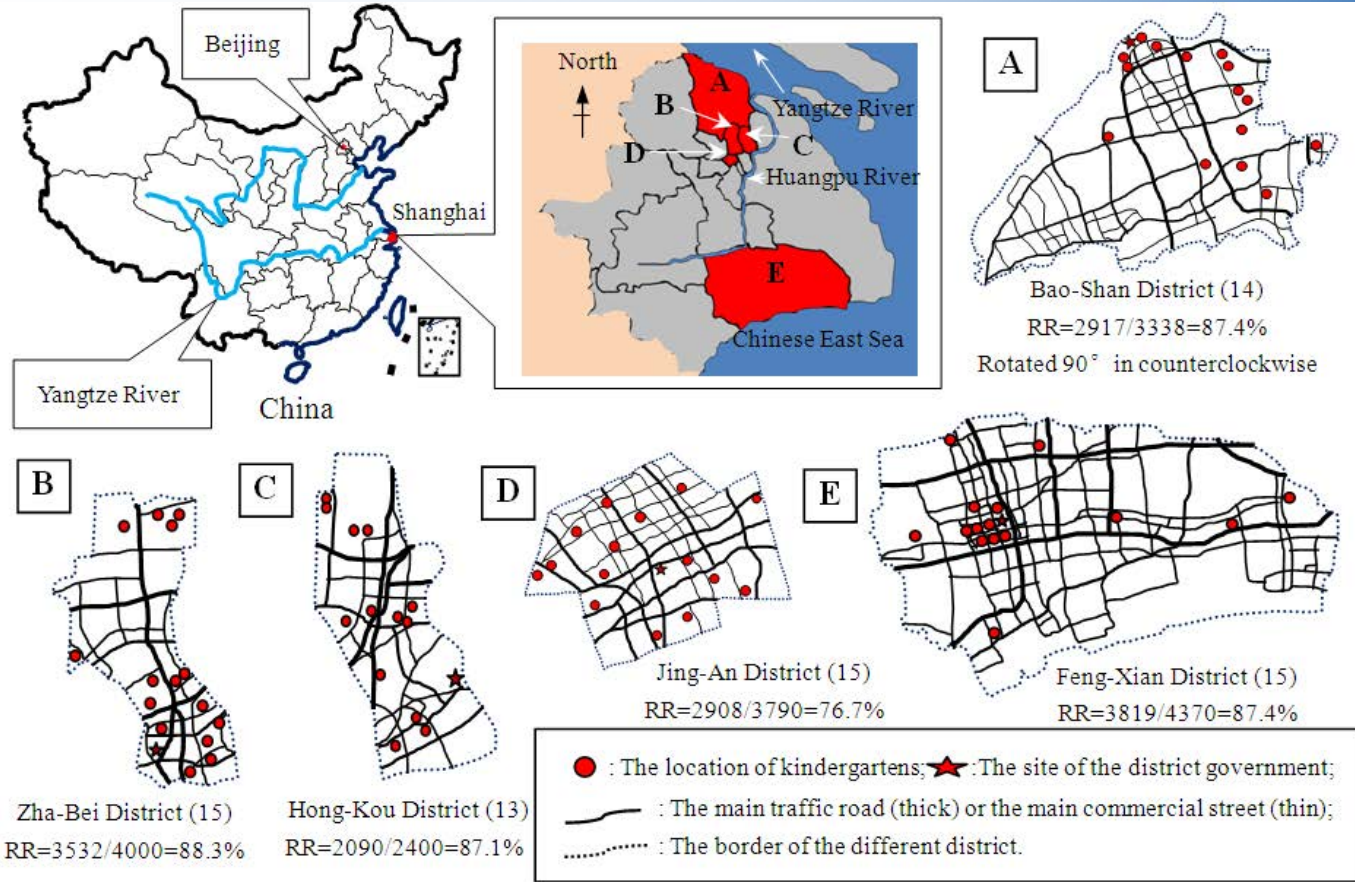

4

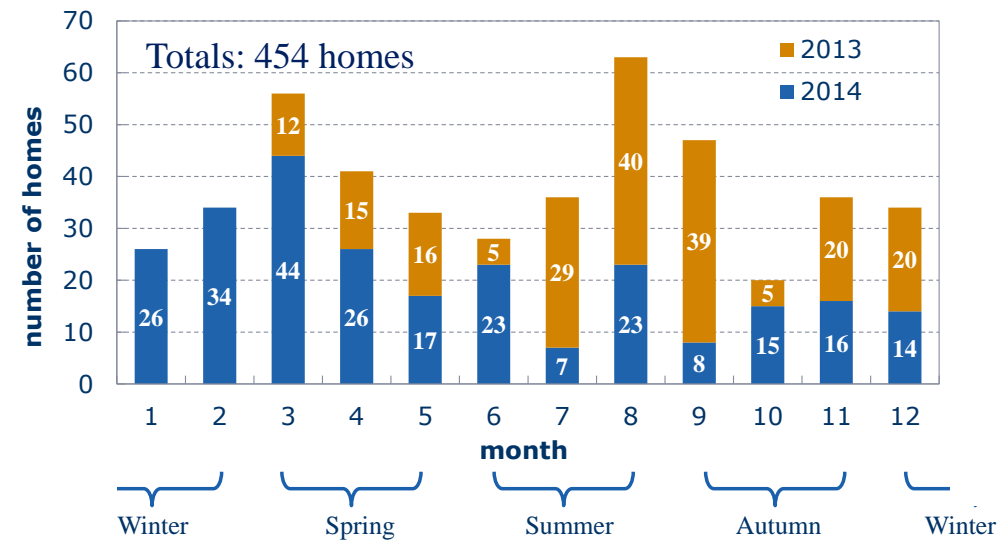

# FIRST MEASUREMENT CAMPAIGN

## END OF MAIN CONSTRUCTION WORKS

- No painting
- No floor
- No ventilation
- No wooden stairs
- No door
- No electricity
- Liquids and powders stocked on the ground floor





# FIRST MEASUREMENT CAMPAIGN

## RESULTS

$\mu\text{g}/\text{m}^3$	BR 1	BR 3	BR 2 - Window	BR 2 - Back	LR - GF	Ext
Formaldehyde	27	25	24	25		< 5
TVOC *	1850	2200	1750	2000	1500	100
Main compounds *: Hexylene glycol / propylene glycol (solvents)	1400	1700	1300	1600	1100	< 20
Sum BTEX ** (solvents, adhesives, ..., and external pollution)	210	215	200	210	180	< 20
Benzene	6	6	6	6	3	< 2

\* = approx.    \*\* BTEX = benzene, toluene, ethylbenzene, xylenes

- Low external concentrations: no pollution → the measured concentrations are really specific of the interior
- **Very low formaldehyde concentrations** (24 / 27  $\mu\text{g}/\text{m}^3$ )
- **Very high TVOC concentrations** (> 1500  $\mu\text{g}/\text{m}^3$  in toluene equivalent – approx.), mainly due to the solvents and cleaning products used and stocked, and to the sewer connection
- **No target value before the house is actually lived-in.**

# SECOND MEASUREMENT CAMPAIGN

## AFTER MAIN INTERIOR FINISHING

- No painting
- Floor installed
- Ventilation installed and used for 2 weeks
- Stairs installed
- Most doors installed
- Electricity OK
- Almost all stocked products removed  
(Some tiles adhesive still stocked in the bathroom)



# SECOND MEASUREMENT CAMPAIGN

High comfort

Comfort

Basic

## RESULTS

$\mu\text{g}/\text{m}^3$	BR 1	BR 3	BR 2 - Window	BR 2 - Back	LR - GF	Ext
Formaldehyde	13	18	14	13	15	-
TVOC	240	220	270	295	160	-
Main compound: pentadiene-type VOC (4-Methyl-1,3- pentadiene, ...)	140	130	160	180	100	-
BTEX	$\leq 20$	$\leq 20$	$\leq 20$	$\leq 20$	$\leq 20$	-
Benzene	$< 3$	$< 3$	$< 3$	$< 3$	3	-

- No external concentrations measurements because of rain
- **Even lower formaldehyde concentrations** (14 / 18  $\mu\text{g}/\text{m}^3$ )
- **Strongly reduced TVOC concentrations** (220 – 300  $\mu\text{g}/\text{m}^3$  in toluene equivalent) mainly because of the ventilation. Residual COV due to floor coating and wooden stair varnish.
- Benzene concentrations lower than 5  $\mu\text{g}/\text{m}^3$  value defined by HQE 2015 protocol

# CONCLUSIONS

## IAQ IS BAD DURING CONSTRUCTION PHASE

- No ventilation
- Due to specific products (solvents...)
- No link with IAQ in finished house
- May affect workers health

## IAQ CAN BE EASILY IMPROVED AT THE END OF CONSTRUCTION PHASE

- By removing pollutant sources (paint pot, glue...)
- With ventilation

## NEXT STEP

- Measurements after 10 months of occupation
- Q4 2017

# Subtask Contributions to Flow of Design

<p>Performance requirements</p>	<p>Requirements for IAQ based on current standards, particular building codes in different countries, as well as newly developed metrics based on health effects.</p>	<p>Input from state of the art review and SUBTASK 1</p>
<p>Design proposal</p>	<p>Type of ventilation system (hybrid, decentralized, active overflow, etc.); air supply mode (intermittent/ vs. continuous) with respect to different building types.</p>	<p>Input from state of the art and SUBTASK 5</p>
<p>Performance prediction</p>	<p>Modelling, simulation models/routines usable by practitioners, IAQ benchmarking, labelling schemes.</p>	<p>Input from SUBTASK 2 and SUBTASK 3</p>
<p>Performance desirable?</p> <p>No</p> <p>Yes</p>	<p>Subtask 4 is not intending to address decision making process directly, however it will make suggestions on methodology for data analysis that supports decision making</p>	<p>Input from SUBTASK 1, SUBTASK 3 and SUBTASK 5</p>
<p>Final design &amp; Construction</p>	<p>Application of recent advances in sensor technology and model based control to optimize the indoor air quality without penalizing on the energy efficiency.</p>	<p>Input from SUBTASK 1 and SUBTASK 5</p>
<p>Operation</p>		

# Deliverables

- Documentation of metrics for the IAQ and energy field
- A practically applicable design guidebook on operational control strategies for residential buildings
- Documentation of field tests and case studies
- Report on modelling framework and design tools
- Emission source and sink models + database

Overall, the project shall deliver data and tools that are to be used by designers, manufacturers and practitioners!



# Results and deliverables

- D1: **Subtask 1 Report** on *Metrics for high IAQ and energy efficiency in residential buildings*
- D2: **Subtask 2 Report** on *Pollutant loads in energy efficient residential buildings under in-use conditions*
- D3: **Subtask 3 Report** on *Modelling of IAQ and energy efficiency - review, gap analysis & categorization*
- D4: **Subtask 4 Report** on *Guidebook on design and operation for high IAQ in energy efficient residential buildings*
- D5: **Subtask 5 Report** on *Field tests and case studies – documentation of residential buildings*
  
- D6: A **database** on *Storage and transport properties of materials for use in models*
- D7: A **database** on *Pollution loads in existing buildings.*

# Target Audience

The project addresses the following stakeholders:

- Building designers (engineers and architects)
- Suppliers of HVAC and control systems
- Suppliers of materials used in building construction and indoor furnishing
- Providers of building management systems

The project shall also address the interests of building owners, facility managers and users, as well as authorities



# Participating Countries

- Austria
- Belgium
- China
- Canada
- Czech Republic
- Denmark
- Estonia
- France
- Germany
- the Netherlands
- Norway
- United Kingdom
- USA

# Subtask leadership

	Subtask leader	Co-lead
<b>ST1 – Metrics</b>	France (Abadie)	Denmark (Wargoeki)
<b>ST2 – Pollutant loads</b>	China (Qin)	USA (Zhang)
<b>ST3 – Modeling</b>	Germany (Grunewald)	USA (Zhang)
<b>ST4 – Strategies</b>	Denmark (Kolarik)	Norway (Cao)
<b>ST5 – Field tests and case studies</b>	Belgium (Jelle)	Canada (Fitsum)



# Questions and more information



**5th Expert Meeting of the International Energy Agency,  
Annex 68: Indoor Air Quality Design and Control in Low  
Energy Residential Buildings**

**SCHEDULE:**

Sunday 25<sup>th</sup>- Tuesday 27<sup>th</sup> March 2018

Carsten Rode, Operating Agent

[car@byg.dtu.dk](mailto:car@byg.dtu.dk)

<http://www.iea-ebc-annex68.org/>